

**RYOBI ELECTRIC CULTIVATOR
MODEL NUMBER RY46501B**

FIGURE A

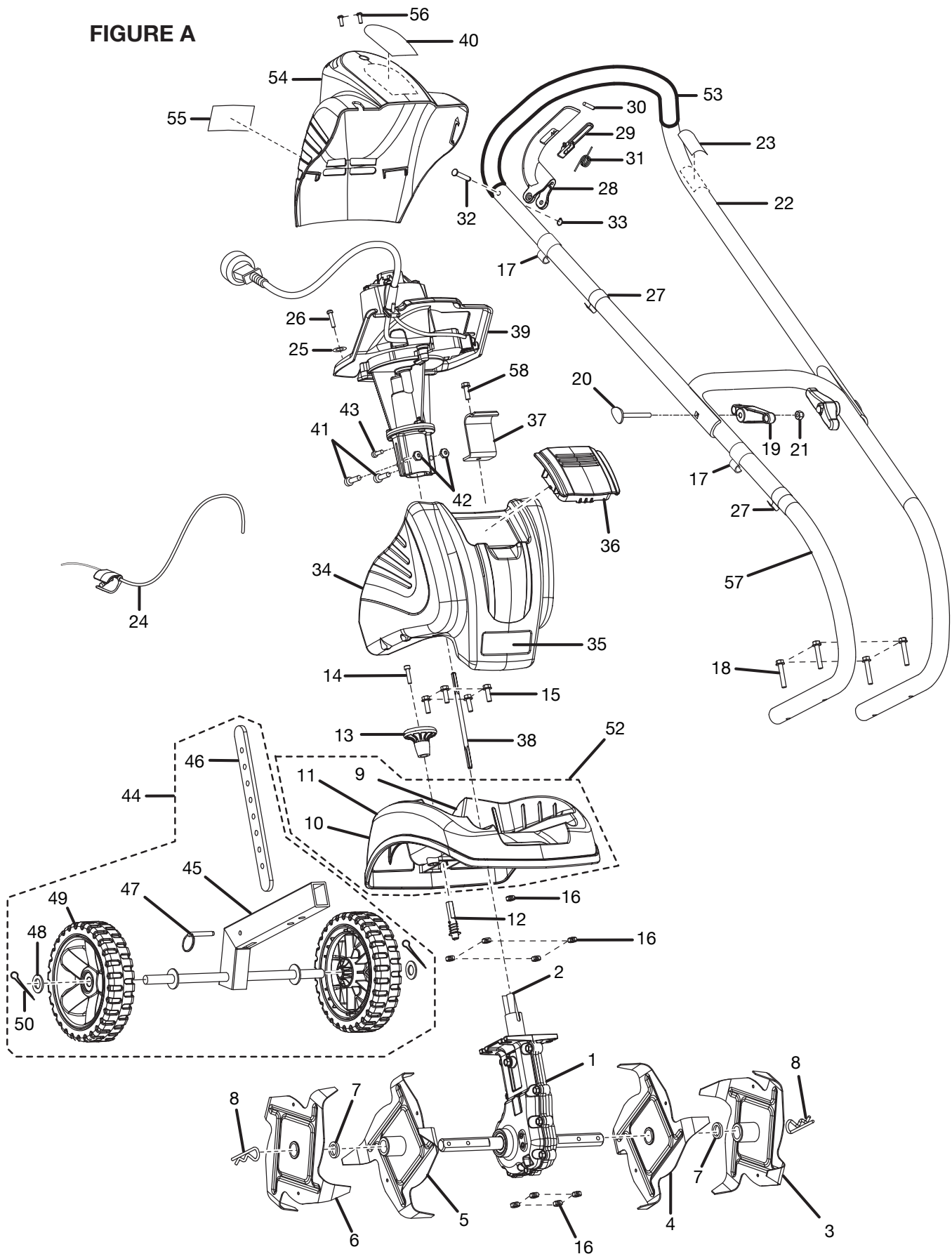

RYOBI ELECTRIC CULTIVATOR MODEL NUMBER RY46501B

The model number will be found on a plate attached to the motor housing. Always mention the model number in all correspondence regarding your **ELECTRIC CULTIVATOR** or when ordering repair parts.

PARTS LIST FOR FIGURE A

KEY NO.	PART NUMBER	DESCRIPTION	QTY.
1	220032001	GEAR BOX ASSY W/TUBE AND LINER.....	1
2	518279001	LINER-HELIX (47 mm).....	1
3	308216002	TINE ASSEMBLY (A).....	1
4	308216003	TINE ASSEMBLY (B).....	1
5	308216004	TINE ASSEMBLY (C).....	1
6	308216005	TINE ASSEMBLY (D).....	1
7	900755001	FELT WASHER	2
8	638001004	CLEVIS CLIP	2
9	950119001	WARNING LABEL (BACK LEFT).....	1
10	950124002	WARNING LABEL (BACK RIGHT)	1
11	950119010	WARNING LABEL (FOOT)	1
12	308228001	RECEIVER RETAINER ASSEMBLY.....	1
13	518206001	KNOB	1
14	660713001	* SCREW (M5 x 16 mm SOC. WASHER HD. CAP)	1
15	660643002	* BOLT (1/4-20 x 3/4 in. HEX HD.)	4
16	678132001	* LOCK NUT (1/4-20)	9
17	518307001	PLASTIC CLIP	2
18	660643001	* BOLT (HANDLE) (1/4-20 x 1-1/2 in. HEX HD.).....	4
19	518190001	KNOB (1/4-20).....	2
20	660711002	* CARRIAGE BOLT (1/4-20 x 2-1/4 in.).....	2
21	678142001	* NUT-ACORN, CENTERLOCK (1/4-20)	2
22	000998260	HANDLE, UPPER ASSEMBLY W/GRIP AND LABEL (INC. KEY NOS. 17, 23, 27 & 53)	1
23	950124004	BOOM LABEL	1
24	308293002	THROTTLE CABLE ASSEMBLY	1
25	678195001	WASHER (FOR ATTACHING THROTTLE CABLE TO MOTOR).....	1
26	660734001	* SCREW (M4 x 16 mm) (FOR ATTACHING THROTTLE CABLE TO MOTOR).....	1
27	518489001	CLIP.....	2
28	518280001	TRIGGER.....	1
29	518281001	LOCK OUT LEVER	1
30	638138001	PIN.....	1
31	638139001	SPRING	1
32	638132001	CLEVIS PIN	1
33	678135001	RETAINING RING	1
34	308217001	TANK, BALLAST ASSEMBLY (INC. KEY NO. 35).....	1
35	950119004	LOGO LABEL	1
36	360992001	LID	1
37	638099001	MOUNTING BRACKET.....	1
38	620388001	DRIVE SHAFT.....	1
39	230128001	MOTOR AND PINION ASSEMBLY	1
40	950124003	LABEL, ELECTRIC AMP LOGO	1
41	660429001	* SCREW (M5 x 19 mm SOC. HD. CAP).....	2
42	678213001	* SQUARE NUT (M5).....	2
43	660669001	* SCREW (8-16 x 1/2 in. PAN HD.)	1
44	308213002	WHEEL/DRAG STAKE ASSEMBLY (INC. KEY NOS. 45, 46, 47, 48, 49 AND 50).....	1
45	308222001	FRAME ASSEMBLY	1
46	638017004	DRAG STAKE	1
47	638017003	HITCH PIN	1
48	638017002	WASHER	2
49	308236001	WHEEL ASSEMBLY	2
50	638635001	* COTTER PIN.....	2
51	950124005	HANG TAG, WHEEL ASSEMBLY (NOT SHOWN).....	1
52	308367001	TINE SHIELD ASSEMBLY (INC. KEY NOS. 9,10 AND 11)	1
53	518053002	GRIP	1
54	000998262	REAR HOUSING ASSEMBLY (INC. KEY NOS. 40 & 55).....	1
55	940729003	DATA LABEL	1
56	660734001	* SCREW (M4 x 13 mm TF).....	2
57	000998261	LOWER HANDLE ASSEMBLY (INC. KEY NO. 17).....	1
58	660714002	BOLT (1/4-20 X 5/8 in.).....	1

* Standard Hardware Item – May Be Purchased Locally

**RYOBI ELECTRIC CULTIVATOR
MODEL NUMBER RY46501B**

FIGURE B

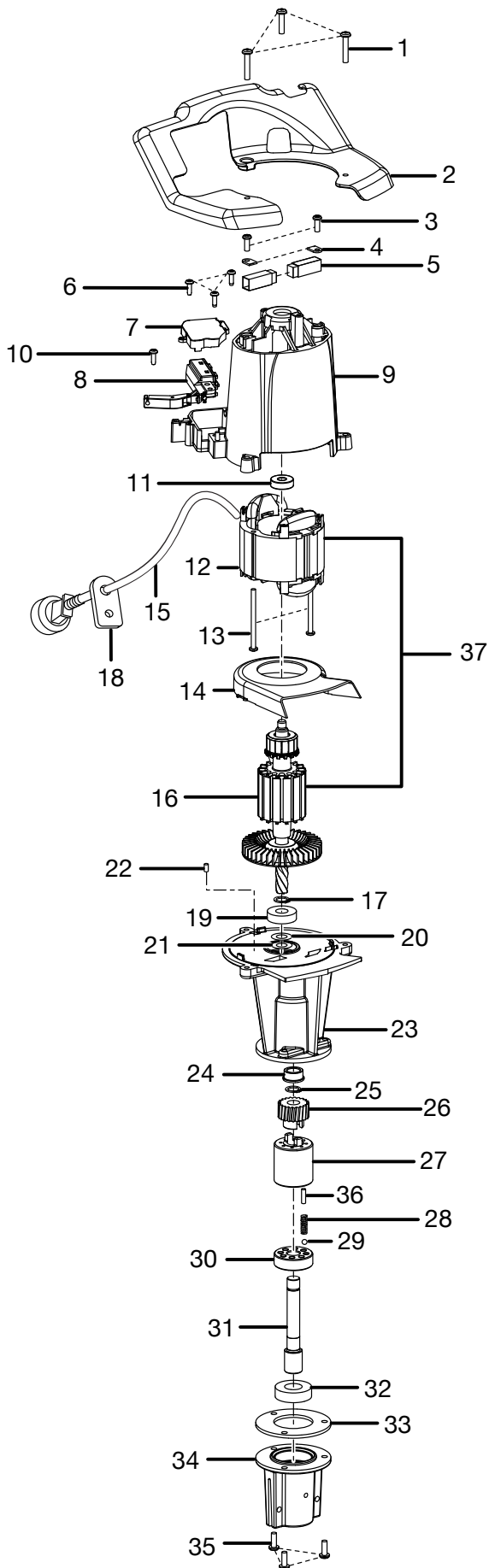

**RYOBI ELECTRIC CULTIVATOR
MODEL NUMBER RY46501B**

The model number will be found on a plate attached to the motor housing. Always mention the model number in all correspondence regarding your **ELECTRIC CULTIVATOR** or when ordering repair parts.

PARTS LIST FOR FIGURE B

KEY NO.	PART NUMBER	DESCRIPTION	QTY.
1	660434001	* SCREW (M5 X 26 mm).....	3
2	513361001	INNER HOUSING.....	1
3	6631303	* SCREW (8-16 x 5/8 in. PAN HD.).....	2
4	630801001	BRUSH TUBE CLAMP.....	2
5	290075001	BRUSH TUBE ASSEMBLY.....	2
6	660164001	* SCREW (M3.5 X 16 mm).....	3
7	513360001	SWITCH COVER.....	1
8	760245004	SWITCH, ON-OFF ASSEMBLY.....	1
9	513359001	MOTOR HOUSING.....	1
10	6620802	SCREW (M4 x 12 mm PAN HD.).....	1
11	680141001	BALL BEARING (NTN 608ZZ C3/1E).....	1
12	740763001	FIELD ASSEMBLY.....	1
13	660101004	* SCREW (8-10 X 2-1/2 in. PAN HD.).....	2
14	513363001	FAN SHROUD.....	1
15	730377019	POWER CORD.....	1
16	740764001	ARMATURE ASSEMBLY.....	1
17	680336001	RETAINING RING.....	2
18	570569001	GROMMET.....	1
19	T690395001	BALL BEARING.....	1
20	900721001	FELT SEAL.....	1
21	900098001	FIBER WASHER RING.....	1
22	550339001	RUBBER PLUG.....	1
23	640958004	GEAR BOX.....	1
24	670058002	FLANGE BEARING.....	1
25	671829001	WASHER.....	1
26	610481001	GEAR.....	1
27	671739001	CLUTCH.....	1
28	671743001	SPRING.....	8
29	671400003	BALL (5.96 mm).....	8
30	670514002	CLUTCH PLATE.....	1
31	620403001	OUTPUT SHAFT.....	1
32	680769004	BALL BEARING (6003).....	1
33	901110001	GASKET.....	1
34	640958003	GEAR CASE.....	1
35	660430001	* SCREW (M5 x 14 mm).....	3
36	690009001	PLUG (6 mm x 17 mm).....	8
37	290147007	MOTOR ASSEMBLY (INC. KEY NOS. 12 AND 16).....	1
	983000884	OPERATOR'S MANUAL (960994003)	
	983000885	REPLACEMENT PARTS LIST (961032005)	
	983000884R	REPAIR SHEET (REV:03)	
	12-18-07		

* Standard Hardware Item – May Be Purchased Locally