

ELECTRIC TOOL PARTS LIST

■ DISC SANDER
Model S 18SB

2006 · 2 · 1

(E1)

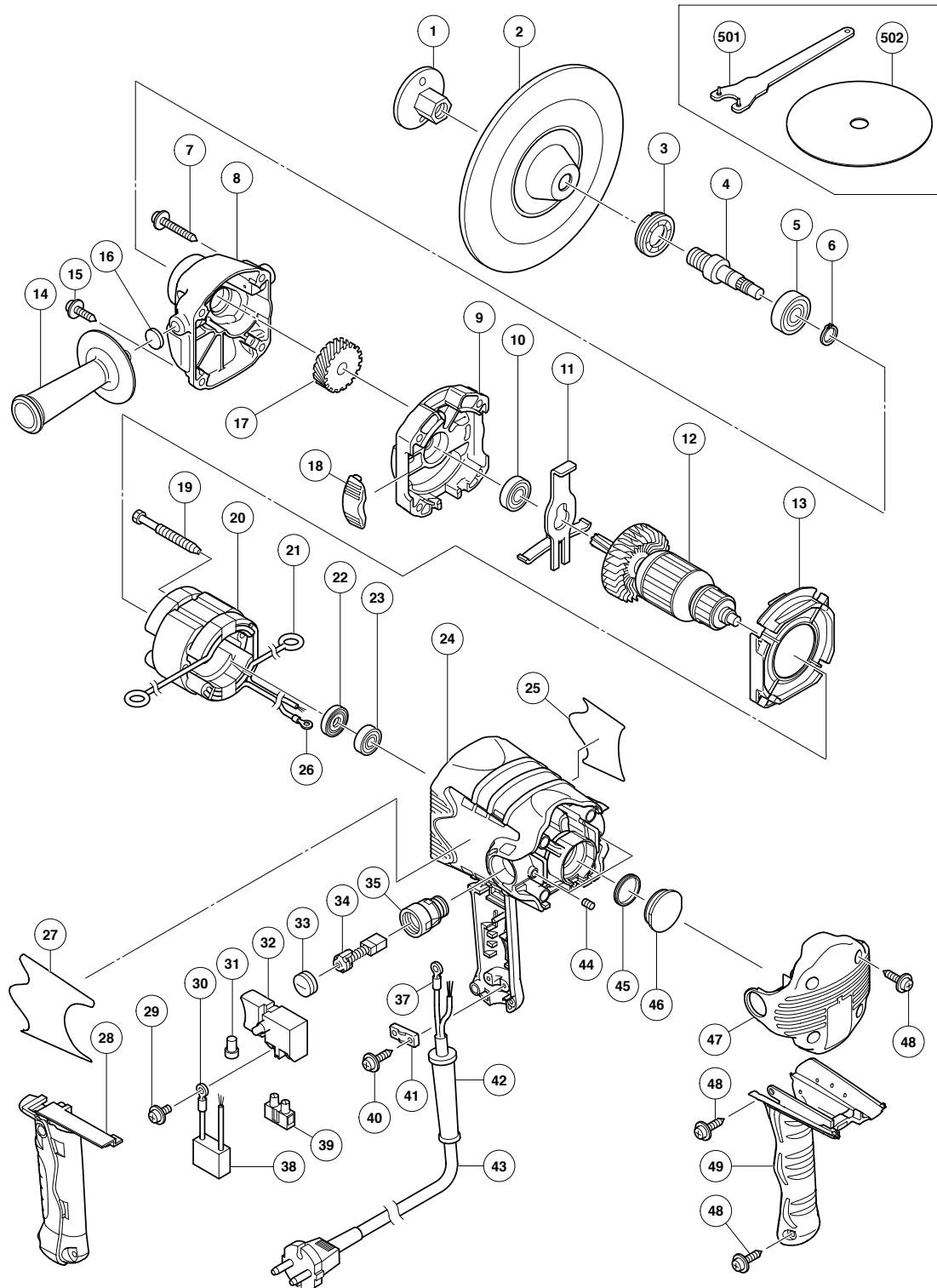

PARTS

S 18SB

ITEM NO.	CODE NO.	DESCRIPTION	NO. USED	REMARKS	
* 1	953-381	WASHER NUT	1		
* 1	953-246Z	WASHER NUT M14	1	FOR EUROPE	
* 1	953-254P	WASHER NUT 5/8"-11UNC	1	FOR USA, CAN	
* 2	953-255	RUBBER PAD (D16 HOLE)	1		
* 2	953-247Z	RUBBER PAD (D14 HOLE)	1	FOR EUROPE	
	3	325-857	BEARING CAP	1	
* 4	325-501	SPINDLE (B)	1		
* 4	325-502	SPINDLE (B)	1	FOR EUROPE	
* 4	325-503	SPINDLE (B)	1	FOR USA, CAN	
	5	620-1DD	BALL BEARING 6201DDCMPS2L	1	
	6	939-542	RETAINING RING FOR D12 SHAFT (10 PCS.)	1	
	7	309-778	TAPPING SCREW (W/FLANGE) D5X55 (BLACK)	2	
	8	325-499	GEAR COVER ASS'Y	1	INCLUD. 16
	9	325-498	INNER COVER	1	
	10	600-0DD	BALL BEARING 6000DDCMPS2L	1	
	11	325-477	LOCK LEVER	1	
* 12	360-758U	ARMATURE ASS'Y (D) 120V	1	INCLUD. 10, 22, 23	
* 12	360-758E	ARMATURE (D) 220V-230V	1		
* 12	360-758F	ARMATURE (D) 240V	1		
	13	325-474	FAN GUIDE	1	
	14	994-322	SIDE HANDLE	1	
	15	323-209	TAPPING SCREW (W/FLANGE) D5X35 (BLACK)	2	
	16	937-033	FELT WASHER	2	
	17	325-500	FIRST GEAR	1	
	18	328-483	AIR COVER	1	
	19	992-509	HEX. HD. TAPPING SCREW D5X45	2	
* 20	340-656C	STATOR ASS'Y (D) 120V	1	INCLUD. 21, 26	
* 20	340-656E	STATOR ASS'Y (D) 220V-230V	1	INCLUD. 21, 26	
* 20	340-656G	STATOR ASS'Y (D) 220V-230V	1	INCLUD. 21, 26 FOR EUROPE, CHN	
* 20	340-656F	STATOR ASS'Y (D) 240V	1	INCLUD. 21, 26	
	21	930-703	BRUSH TERMINAL	2	
	22	315-877	DUST SEAL	1	
	23	608-VVM	BALL BEARING 608VVC2PS2L	1	
	24	325-492	HOUSING ASS'Y	1	INCLUD. 35, 44-46
	25		NAME PLATE	1	
	26	980-063	TERMINAL	1	
	27		HITACHI LABEL	1	
	28	325-481	HANDLE COVER	1	
	29	305-499	MACHINE SCREW (W/WASHER) M3.5X6	2	
* 30	980-063	TERMINAL	1	FOR NOISE SUPPRESSOR	
* 31	959-140	CONNECTOR 50091 (10 PCS.)	1	FOR USA, CAN, INA, SIN	
	32	305-409	SWITCH (A) (1P PLUG IN TYPE) W/O LOCK	1	INCLUD. 29
	33	945-161	BRUSH CAP	2	
	34	999-043	CARBON BRUSH (1 PAIR)	2	
	35	958-900	BRUSH HOLDER	2	
	37	980-063	TERMINAL	1	FOR CORD
* 38	930-039	NOISE SUPPRESSOR	1	FOR EUROPE, CHN	
* 39	938-307	PILLAR TERMINAL	1	FOR EUROPE, MAL, CHN	
	40	984-750	TAPPING SCREW (W/FLANGE) D4X16	2	
	41	937-631	CORD CLIP	1	
	42	953-327	CORD ARMOR D8.8	1	

