

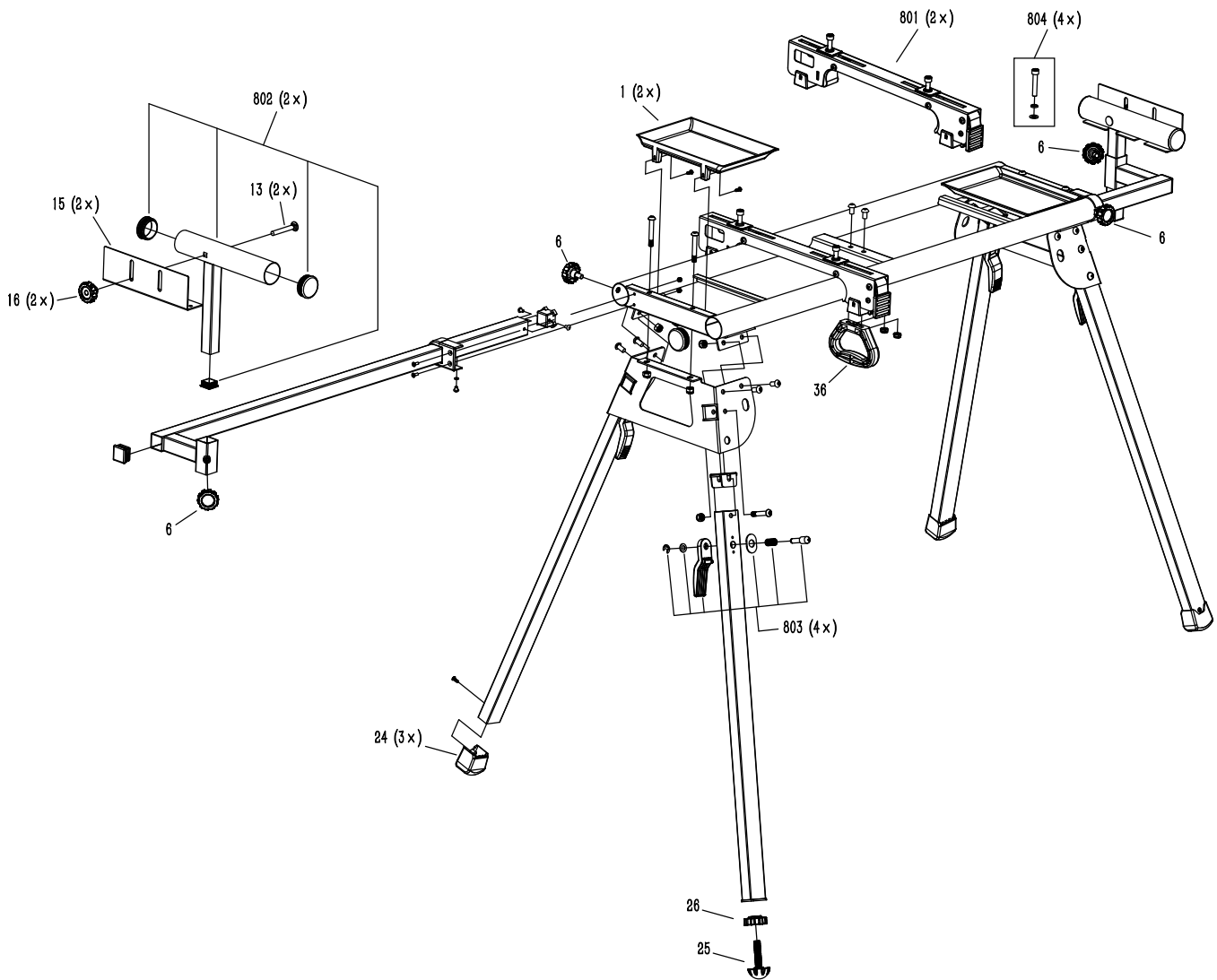

Product Description: Folding Stand  
Model Number: SPT5002-FS  
Body Number: 0180001002  
Version: A  
Issue Date: 2020/02/13



No.	Product Model#	Part Number	Description	Qty
1	SPT5002-FS	3130253411	Storage tray	2
6	SPT5002-FS	3130253412	M8x35 knob	4
13	SPT5002-FS	5610361284	Carriage Bolt	2
15	SPT5002-FS	3706973120	Work stop	2
16	SPT5002-FS	3130253413	Knob M8	2
24	SPT5002-FS	3130253414	Feet pad	3
25	SPT5002-FS	3130253415	Adjust Feet Pad	1
26	SPT5002-FS	3130253416	Adjustabled screw	1
36	SPT5002-FS	3130253417	Handle	1
801	SPT5002-FS	2826622258	Saw mounting bracket ass'y	2
802	SPT5002-FS	2826622259	Work support ass'y	2
803	SPT5002-FS	2826622260	Leg lock handle ass'y	4
804	SPT5002-FS	2826622261	screw set	4