

MODEL: SS-5020S

SureShot 5020S

Key#	Unique#	Description#	Key#	Unique#	Description#
1	1015317	Screw	27	501450	Spring
3	1015324	Deflector	28	1015332	Trigger Valve
4	1015329	Exhaust Gasket	29	501415	O-Ring
5	1015322	Cap	30	1015304	O-Ring
6	1015326	Gasket	31	510451	Valve Bushing
7	1015340	Spring	32	501452	Trigger
8	1015303	O-Ring	33	1015335	Pin
9	1015312	O-Ring	34	1015342	Nose Plate
10	1015331	Valve Assembly	35	1015323	Silencer
11	1015311	O-Ring	36	1015314	Screw
12	1015306	O-Ring	37	1015334	Support Bracket
13	1015330	Valve Ring	38	501696	Screw
14	1015308	O-Ring	39	1015298	Cover
15	1015309	Piston Ring Kit	40	1015300	Pusher
16	1015327	Piston	41	1015348	Latch
17	1015297	Driver Blade	42	1015338	Spring
18	1015325	Cylinder	43	1015336	Pin
19	1015307	O-Ring	44	1015319	Elastic Ring
20	1015328	Bumper	45	1015299	Slider
21	1015321	Handle Assembly	46	1015310	Gasket
22	1015305	O-Ring	47	1015341	Spring
23	1015316	Screw	48	1015428	Pin
24	501453	Screw	49	501454	Bushing
25	501746	Nose Plate	50	501462	Spring
26	1015318	Ball	51	501455	Work Contact

* = New Part
< = Part Change

SAFETY: A pair of safety glasses that meets ANSI Z87.1 requirements must always be worn when using this tool. The use of proper eye protection has been shown to significantly reduce eye injuries. Complete safety training is available from your DUO-FAST representatives. It includes a wide range of safety materials to help keep safety awareness high throughout the work area.

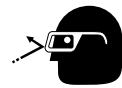

SEGURIDAD: Un par de gafas de seguridad que cumplen con los requerimientos ANSI Z87.1 deber ser siempre usados con el uso de esta herramienta. El uso de protección ocular adecuada ha mostrado que reduce significativamente las lesiones oculares. Una capacitación completa sobre seguridad está disponible a través de sus representantes de DUO-FAST. La misma incluye una amplia gama de material sobre seguridad para ayudarlo a mantener un alto nivel de conciencia sobre la seguridad en toda el área de trabajo.



WARRANTY: Before buying or using any DUO-FAST tool, read the limited warranty that applies. For warranty details, see the full-line catalog or the warranty information in the tool carton.

GARANTÍA: Antes de comprar o utilizar cualquier herramienta DUO-FAST, lea la garantía limitada que se aplica. Para obtener detalles de la garantía consulte el catálogo de toda la línea o la información sobre la garantía en la caja de la herramienta.

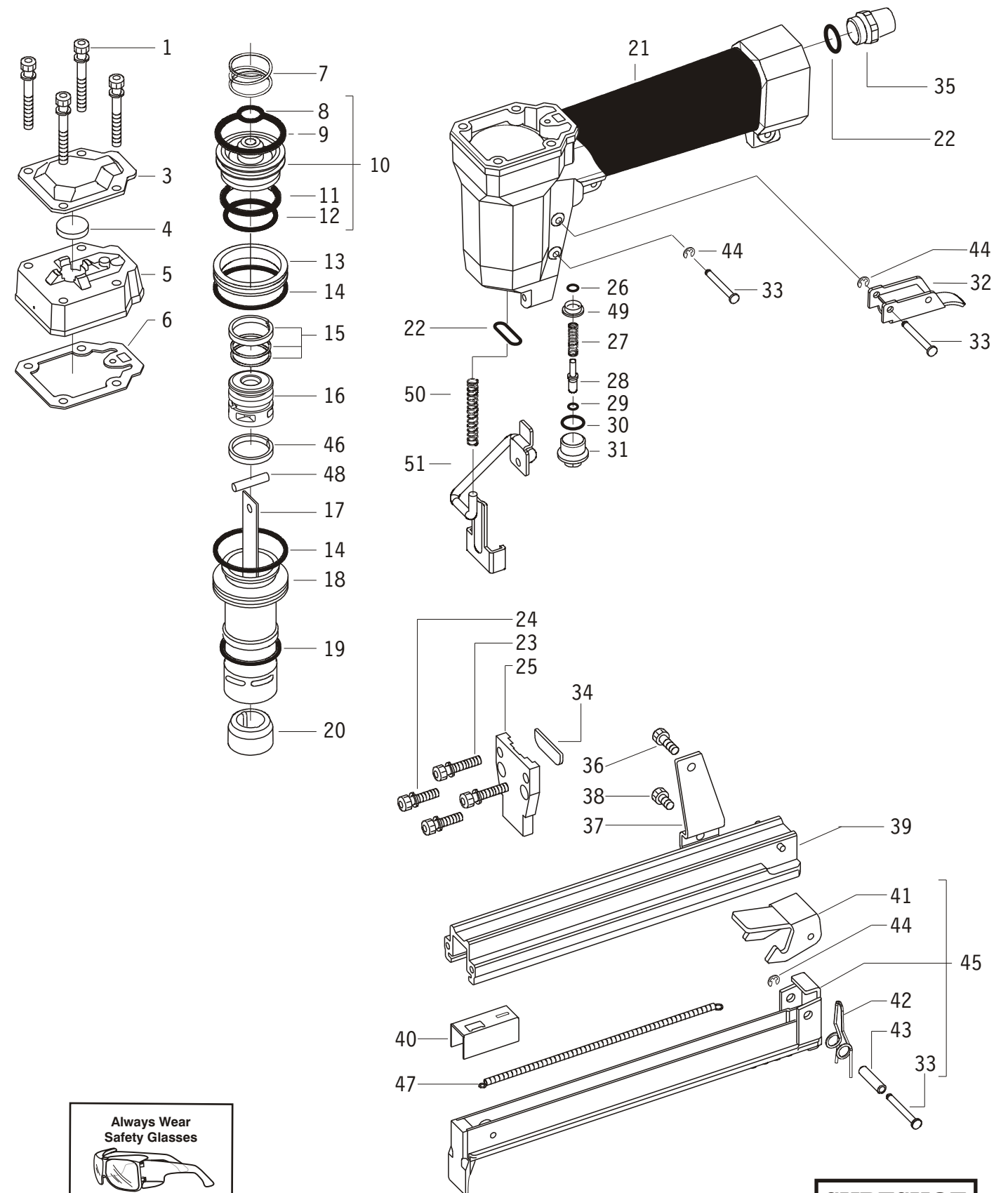

**Always Wear
Safety Glasses**
When Using
Power Tools
402510

**SURESHOT
5020S**